

TEACHER'S ANSWER BOOKLET

Practice for Grade 4 CMT – Packet 2

Please note: This is **not** an official CMT document authorized by the CT State Dept. of Education.

Strand 20 (Statistics and Data Analysis) will **NOT** be tested on the Grade 4 (4th Generation) CMT.

Objective 4E (open-ended number lines) has also been **eliminated** from the Grade 4 (4th Gen) CMT.

Part IV	Obj. 5A – 8A	Pages 2 - 9	8 Pages
Part V	Obj. 9A – 15A	Pages 10 - 17	8 Pages
Part VI	Obj. 16A – 17B	Pages 18 - 24	7 Pages

Name _____ Date _____

Part 4: Review of Strands 5 – 8

(5A)

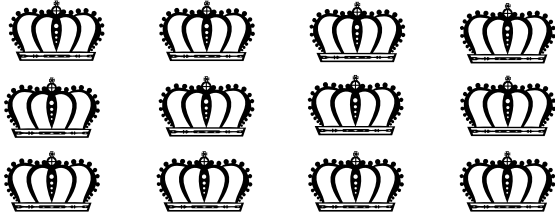

1. The queen placed her crowns carefully in a display case. She had 3 shelves of crowns with 4 crowns on each shelf. Which fact could be used to find the total number of crowns?

- $3 \times 4 = \square$ ***
- $7 \times 4 = \square$
- $5 \times 6 = \square$
- $5 \times 4 = \square$

(5A)

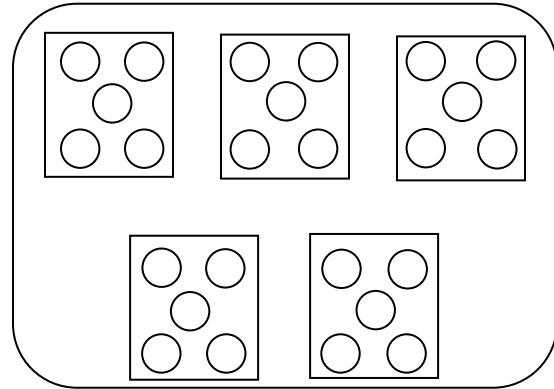

3. Which of the following goes with the picture?

- $18 \div 2 =$
- $25 \div 5 =$ ***
- $16 \div 4 =$
- $21 \div 3 =$

(5A)



2. A starfish has 5 legs. Which equation should be used to discover the number of legs that 8 starfish have?

- $40 + 8 = \square$
- $8 \times 5 = \square$ ***
- $40 - 5 = \square$
- $5 \div 40 = \square$

(5A)

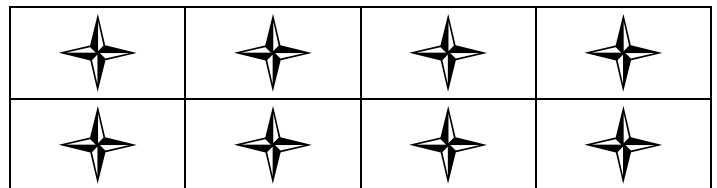

4. Which equation goes with this picture?

- $4 \div 2 = \square$
- $2 + 4 = \square$
- $2 \times 4 = \square$ ***
- $4 - 2 = \square$

(5A)

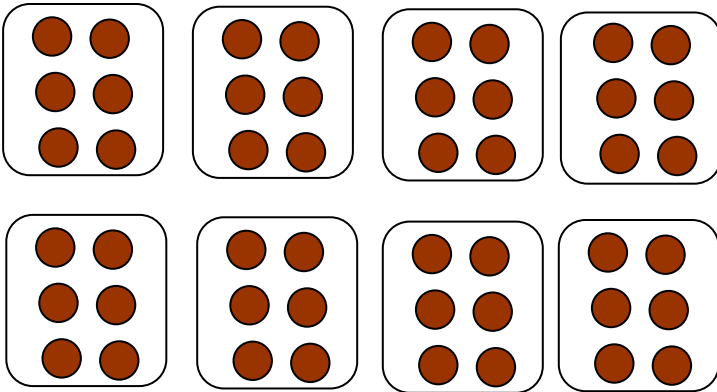

5. Tony baked 48 cookies. He put 6 cookies in each bag. Which number sentence should be used to find out how many bags Tony used?

- $48 + 6 = \square$
- $48 \div 6 = \square$ ***
- $8 - \square = 48$
- $8 \times 48 = \square$

(5A)



6. Heather had 3 pies. She cut each pie into 6 slices. Which equation could be used to find the total number of slices?

- $6 \div 3 = \square$
- $6 + 3 = \square$
- $6 - 3 = \square$
- $6 \times 3 = \square$ ***

(5A)

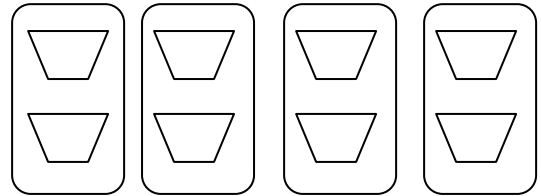

7. Which equation belongs with this picture?

- $8 \div 2 = \square$ ***
- $8 + 2 = \square$
- $8 - 2 = \square$
- $8 \times 2 = \square$

(5A)

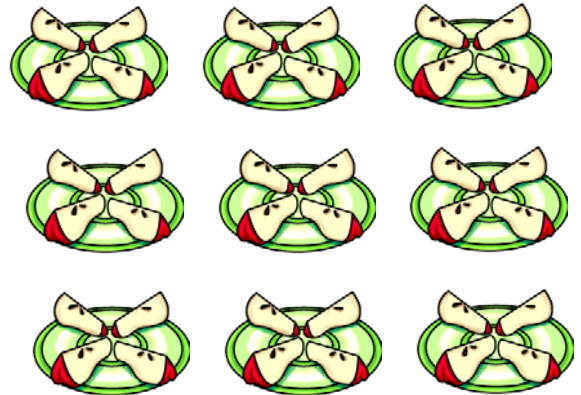

8. Joanne put 4 pieces of apples on a dish. Which number sentence should be used to find out how many pieces of apples would be on 9 dishes?

- $4 + 9 = \square$
- $9 - 4 = \square$
- $4 \times 9 = \square$ ***
- $9 \div 4 = \square$

(5B)

9. Diana decided to share her 96 pencils equally among her three friends and herself. Which number sentence could be used to find out how many pencils each person received?

- $96 + 4 =$
- $96 - 4 =$
- $96 \times 4 =$
- $96 \div 4 =$ ***

(5B)

10. Jordan baked 10 pizzas. Each pizza was cut into 12 equal pieces. To find the total number of pieces, you would

- add 10 to 12.
- subtract 10 from 12.
- multiply 12 by 10. ***
- divide 12 by 10.

(5B)

11. Bryan made 57 points for his team. Garrett made 49 points in the same game. Which equation would be used to find out how many **more** points Bryan made than Garrett?

- $57 + 49 =$
- $57 \times 49 =$
- $57 - 49 =$ ***
- $57 \div 49 =$

(5B)

12. To raise money, students held a car wash. They washed 82 cars this Saturday and 96 cars last Saturday. Which could be used to find out how many cars were washed altogether?

- Add 82 and 96. ***
- Subtract 82 from 96.
- Multiply 82 by 96.
- Divide 96 by 82.

(5B)

13. Alex had \$85. Lucas had \$59. What could you do to find out the number of dollars Lucas needs to have as much money as Alex?

- Multiply 59 by 85.
- Add 59 and 85.
- Subtract 59 from 85. ***
- Divide 85 by 59.

(5B)

14. Paddy buried 18 pots of gold in Bristol. Erin buried 47 pots of gold in Hartford. Which equation should be used to find out how many pots of gold were buried?

- $47 \div 18 = \square$
- $47 + 18 = \square$ ***
- $47 \times 18 = \square$
- $47 - 18 = \square$

(5C)

Scoring Rubric for All 4 Operations – Writing Story Problems

2 Points: The student writes a story problem that matches a given number sentence.

- Situation followed by a question appropriate for the number sentence
- Correct numbers stated in situation, or number incorrect due to recording error
- Question implied rather than stated

1 Point: The student translates a number sentence to a situation that is not appropriate for the specified operation.

- Inappropriate situation followed by a question that requires the given operation
- Situation given, but question is neither stated nor implied

0 Points: The student does not write a story problem that matches a given number sentence.

- A "story" about the number sentence
- A statement about the number sentence
- Situation and question too vague to determine operation
- Number sentence copied
- Number sentence solved

15. Write a story problem than can be solved using the number sentence $52 - 28 =$.

TAKE-AWAY MODEL: Joe had 52 cupcakes (which he didn't need because he had a toothache.) He gave 25 to Mary (because he really likes her and hopes she'll go out with him.) How many cupcakes does Joe still have?

COMPARISON MODEL: Joe has 52 suits (because he is overly concerned with material possessions.) Alan has 25 suits (which he'll probably sell anyway because he is on a high spiritual plane – in other words, he lost his job and needs the money.) How many more suits does Joe have than Alan?

MISSING ADDEND MODEL: Mary has 52 diamond rings in her collection. (Like she's really going to date someone just to get cupcakes? I don't think so.) Suzie Q has 25 diamond rings. How many diamond rings does Suzie need to have as many as Mary has?

COMBINED MODEL: Eleanora has 52 milk chocolate and white chocolate candy bars. 25 of those candy bars are milk chocolate. How many are white chocolate?

16. Write a story problem that can be solved using the number sentence $36 + 18 =$.

JOINING MODEL: Guido has 36 lawn mowers in his shed. (A little obsessed with that lawn, are we?) Last week he bought 18 new lawn mowers. Now how many lawn mowers does he have? (And WHY?)

COMBINED MODEL: Guido has 36 lawn sprinklers. His brother, Daniello, has 18 lawn sprinklers. (Lawn obsession obviously runs in the family. Don't even ask what Cousin Bruno has for his lawn.) How many lawn sprinklers do the two brothers have?

17. Write a story problem that can be solved using the number sentence $6 \times 5 =$.

REPEATED ADDITION MODEL: Eleanora makes \$6 an hour (which explains why she has candy bars and Mary has diamond rings.) If she works for 5 hours, how much money will she earn?

ARRAY MODEL: Mary decides to display some of her emerald necklaces. She uses 5 shelves in one closet and puts 6 necklaces on each shelf. (Talk about conspicuous consumption – Mary's the poster child!) How many necklaces does Mary have on display?

CARTESIAN PRODUCTS MODEL: Mary (who has way too much time on her hands and needs to donate time to helping teachers in her community correct papers and run off dittos) decided to check out her clothes closet. She found 5 skirts and 6 blouses she hadn't worn in a while. How many outfits could Mary make by combining one blouse with one skirt?

18. $7 \times 4 =$ (6A) 22. $236 + 58 =$ (7A)
- 24 178
- 28 *** 294 ***
- 32 321
- 36 816

19. $\begin{array}{r} 9 \\ \times 4 \\ \hline \end{array}$ (6A) 23. $\begin{array}{r} 605 \\ - 263 \\ \hline \end{array}$ (7A)
- 27 342 ***
- 36 *** 363
- 45 442
- 54 462

20. $24 \div 3 =$ (6B) 24. $\begin{array}{r} 692 \\ + 237 \\ \hline \end{array}$ (7A)
- 5 864
- 6 868
- 7 928 ***
- 8 *** 1018

21. $10 \overline{)50}$ (6B)
- 5 *** 7
- 6 8

(7A)

25.

$$804 - 67 =$$

728

732

737 ***

743

25.

$$\begin{array}{r} 72 \\ \times 5 \\ \hline \end{array}$$

310

351

357

360 ***

(7B)

(7B)

23.

$$16 \times 4 =$$

44

64 ***

74

84

26.

$$28 \div 2 =$$

12

14 ***

16

18

(7B)

(7B)

24.

$$3 \overline{)63}$$

17

21 ***

23

27

27.

$$4 \overline{)84}$$

21 ***

22

23

24

(7B)

28 (8A) $\frac{2}{6} + \frac{3}{6} =$ (8A)

$\frac{2}{6}$
 $+$
 $\frac{3}{6}$

$\frac{1}{6}$

$\frac{5}{6}$ ***

$\frac{1}{12}$

$\frac{5}{12}$

$\frac{2}{3}$
 $+$
 $\frac{1}{3}$

$\frac{1}{3}$ ***

$\frac{2}{3}$

$\frac{1}{6}$

$\frac{3}{6}$

29. (8A) $\frac{7}{8} - \frac{3}{8} =$ (8A)

$\frac{7}{8}$
 $-$
 $\frac{3}{8}$

$\frac{1}{2}$ ***

$\frac{3}{4}$

$\frac{5}{8}$

$\frac{4}{16}$

30. (8A)

$\frac{6}{10}$
 $+$
 $\frac{2}{10}$

$\frac{1}{2}$

$\frac{12}{10}$

$\frac{8}{20}$ ***

$\frac{8}{10}$

Name _____ Date _____

Part 5: Review of Strands 9 – 15

(9A)

1. Melanie bought 2 pounds of peaches. If she paid \$1.39 for each pound, how much did Melanie pay for both pounds of peaches?

- \$1.30
- \$2.78 ***
- \$3.40
- \$3.56

I am treating problem 1 as an addition problem, but multiplication beyond the scope of the CMT could be used.

(9B)

3. Alex brought 15 pounds of hamburgers, 19 pounds of chicken, and 30 gallons of lemonade to a picnic. How many pounds of meat did Alex bring to the picnic?

- 34 ***
- 45
- 49
- 64

(9A)

2. Dakota had 6 boxes in his closet. Each box had 12 cowboy hats. How many cowboy hats did Dakota have?

- 2
- 6
- 18
- 72 ***

(9A)

4. Alexandria read a book with 346 pages. Lucas read a book with 532 pages. How many more pages did Lucas's book have than Alexandria's?

- 186 ***
- 196
- 214
- 294

(9A)

5. The fifth graders ordered 356 hot lunches on Monday. They ordered 283 hot lunches on Tuesday. How many hot lunches did they order altogether?

- 533
- 539
- 633
- 639 ***

(9B)

8. Heather bought 9 new pairs of shoes for \$145 and a new hat for \$79. She gave the clerk \$300. How much did she pay for the shoes and hat?

- \$ 76
- \$224 ***
- \$524
- \$533

(9B)

6. Tony has 16 pairs of jeans. Each pair has 3 pockets and 2 patches. How many pockets does Tony have on all his jeans?

- 21
- 32
- 48 ***
- 80

(9A)

9. A Douglas fir tree in Oregon is 329 feet tall. A sugar pine tree in California is 232 feet tall. How much shorter is the sugar pine tree than the Douglas fir?

- 97 ***
- 103
- 111
- 197

(9A)

7. Tommy had 4 boxes. He put 24 match cars in each box. How many match cars did he put in boxes in all?

- 6
- 20
- 28
- 96 ***

(10A)

10. Audrey has \$785. Lily has \$829. Which of the following would be **best** to use to **estimate** how much money they have in all?

- 700 + 800
- 700 + 900
- 800 + 800 ***
- 800 + 900

(10A)

11. Maxwell needs to multiply 23 by 57. Which of the following would be **best** for Maxwell to use to **estimate** the product?

- 20 x 50
- 20 x 60 ***
- 30 x 50
- 30 x 60

(10A)

12. Jackson needs to divide 528 by 37. Which of the following would be **best** for Jackson to use to **estimate** the quotient?

- 500 ÷ 30
- 500 ÷ 40 ***
- 600 ÷ 30
- 600 ÷ 40

(10A)

13. Ian had \$50. He spent \$18.35 on his sister's birthday present. Which of the following would be **best** for Ian to use to **estimate** his change?

- \$10 - \$50
- \$20 - \$50
- \$50 - \$10
- \$50 - \$20 ***

(10A)

14. Carol bought a pair of scissors for \$12.89 and a hammer for \$18.95. Which of the following would be **best** for Carol to use to **estimate** the cost of her two items?

- \$12 + \$18
- \$13 + \$18
- \$12 + \$19
- \$13 + \$19 ***

(10A)

15. Joy has 695 baseball cards, and Sue has 187 baseball cards. Which of the following would be **best** to use to **estimate** how many more cards Joy has than Sue?

- 600 - 100
- 700 - 100
- 600 - 200
- 700 - 200 ***

(11A)

16. At the music store, a saxophone cost \$719 and a clarinet cost \$899. What is a REASONABLE estimate for the cost of the two instruments?

- \$1600 ***
- \$1500
- \$ 200
- \$ 100

(11A)

17. Katie needs 825 yards of red cloth and 398 yards of green cloth to make costumes for the school play. **About** how much cloth does Katie need altogether?

- less than 1000 yards
- between 1000 and 1500 yards **
- between 1500 and 2000 yards
- more than 2000 yards

(11A)

18. Tom bought a *Connect Four Flip* game for \$6.18. He paid with a \$10.00 bill. Which of the following is a **reasonable** estimate for his change?

- a little less than \$3
- a little more than \$3
- a little less than \$4 ***
- a little more than \$4

(11A)

19. Elizabeth bought 5 books ranging in price from \$12 to \$18. Which could be the amount of money the books cost?

- \$ 35
- \$ 70 ***
- \$ 105
- \$ 140

(11A)

20. Tom had \$582. He gave \$395 to his best friend. **About** how much money did he keep?

- Less than \$100
- Between \$100 and \$200 ***
- Between \$200 and \$300
- More than \$300

(11A)

21. Mr. Diaz drove 220 miles on Monday. He drove 199 miles on Tuesday. **About** how many miles did he drive altogether?

- a little less than 300
- a little more than 300
- a little less than 400
- a little more than 400 ***

Use the calendar to answer questions
 22 and 23.

(14A)

JANUARY						
Sun.	Mon.	Tues.	Wed.	Thurs	Fri.	Sat.
			1	2	3	4
5	6	7	8	9	10	11
12	13	14	15	16	17	18
19	20	21	22	23	24	25
26	27	28	29	30	31	

24. Mark painted his fence from 8:30 A.M. to 10:20 A.M. How much time did he spend painting the fence?

- 2 hours, 30 minutes
- 2 hours, 20 minutes
- 1 hour, 30 minutes
- 1 hour, 50 minutes ***

(14A)

22. Maggie's birthday is the fourth Thursday in January. What is the date of her birthday?

- January 16 [3rd Thurs]
- January 19 [3rd Sun]
- January 23 ***
- January 30 [5th Thurs]

(14A)

25. The fourth graders went on a field trip. They left at 9:07 A.M. They returned at 2:36 P.M. How long did the field trip last?

- 4 hours and 58 minutes
- 5 hours and 34 minutes
- 5 hours and 43 minutes ***
- 5 hours and 52 minutes

(14A)

23. Martin Luther King was born on January 15. Which day is that on the calendar above?

- first Wednesday
- second Thursday
- third Wednesday ***
- fourth Thursday

(14A)

26. Katherine finished baking buns at 2:28 P.M. She began 40 minutes earlier. At what time did Becky begin baking buns?

- 1:23 P.M.
- 1:48 P.M. ***
- 1:58 P.M.
- 2:04 P.M.

(14A)

27. Jim flew from New York to Denver. He left at 10:17 a. m. He landed 4 hours and 33 minutes later. At what time did he land?

- 1:35 p. m
- 1:50 p. m
- 2:15 p. m
- 2:50 p. m ***

(14B)

30. Heather read by the pool for 120 minutes. How many hours is that?

- 2 ***
- 3
- 4
- 5

(14B)

28. Kevin watched a movie for 75 minutes. How long is that?

- 1 hour, 10 minutes
- 1 hour, 15 minutes ***
- 1 hour, 20 minutes
- 1 hour, 30 minutes

(14B)

31. Connor can stare without blinking for 60 seconds. How many minutes is that?

- 1 ***
- 2
- 3
- 4

(14B)

29. Cara rode her bike for $1\frac{1}{2}$ hours. How many minutes is that?

- 55
- 70
- 85
- 90 ***

(14B)

32. Anna and her family were on vacation for 2 weeks. How many days is that?

- 10
- 14 ***
- 18
- 21

(15A)

The small toy plane is 4 inches long.

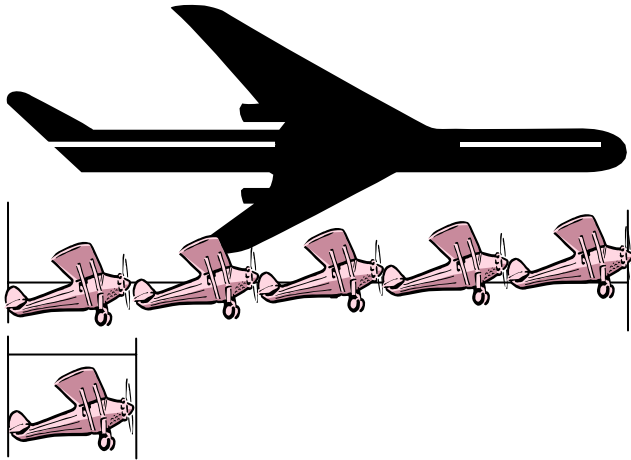

33. **About** how many inches long is the large jet?

5 sm planes x 4 inches
 each = 20 inches

- 10
- 16
- 20 ***
- 30

(15A)

The barbershop sign is 16 inches tall.

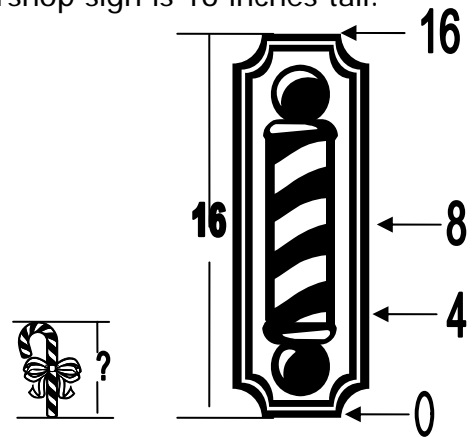

34. **About** how tall is the short candy cane?

- 2 inches
- 4 inches ***
- 6 inches
- 8 inches

(15A)

The long pliers are 12 units long.

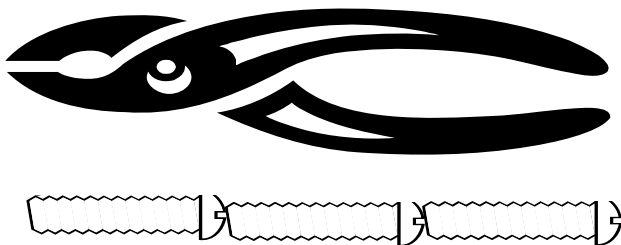

34. **About** how many units long is the short bolt)

12 inches ÷ 3 = 4 in
 or
 4 in + 4 in + 4 in = 12 in

- 2 in
- 4 in ***
- 6 in
- 8 in

(15A)

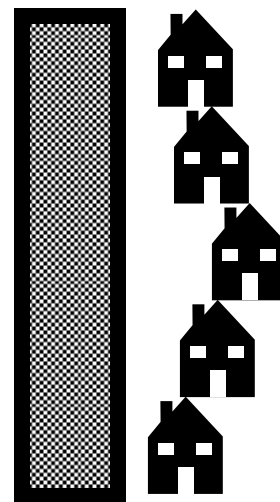

35. The tall tower is **about** how many times as tall as the house?

- 2
- 5 ***
- 8
- 11

(15A)

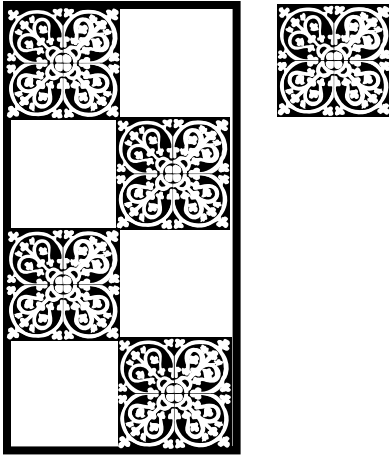

36. **About** how many colored tiles would fill the entire area of the large square?

- 4
- 6
- 8 ***
- 10

(15A)

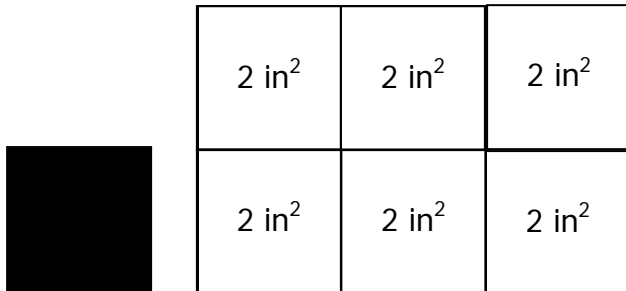

37. If the small shape has an area of 2 square inches, **about** how many square inches is the large shape?

- 8
- 10
- 12 ***
- 14

(15A)

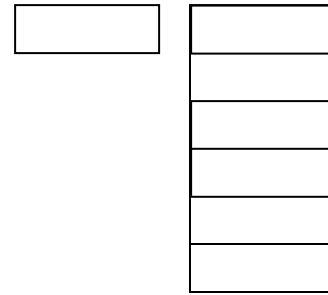

38. **About** how many small shapes would be needed to fill the large shape?

- 3
- 6 ***
- 8
- 10

(15A)

Celia wants to cover her bulletin board with signs she had drawn in art class.

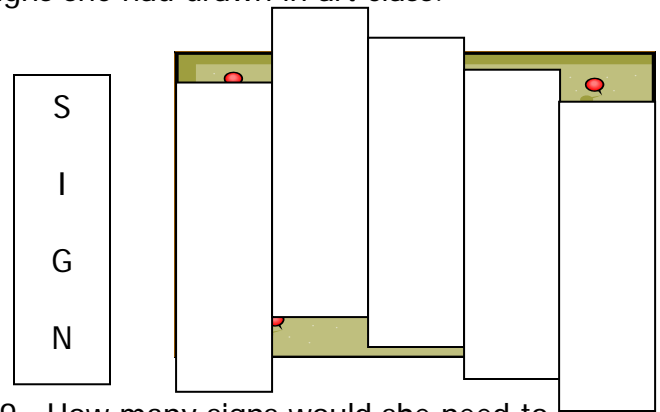

39. How many signs would she need to fill the entire bulletin board?

- 3
- 5 ***
- 7
- 9

Part 6: Review of Strands 16 - 17

The actual rulers students will be required to use for the CMT **will NOT have a black border around the ruler.**

In Grades 3 and 4, children will be measuring with a white ruler on basically white paper.

If a small black line could be drawn around the four sides of the actual rulers, this would help some children to measure more accurately.

If magic marker is used to outline the rulers, care must be taken that the outline is dry before being used for the actual CMT.

Also the black border should not take away from the actual size of the ruler. The length of the ruler starts at the end, and children need to see the actual edge to measure successfully from the edge.

Measuring Rubrics

Obj 16A Must be correct to within $\frac{1}{4}$ inch or $\frac{1}{2}$ cm

Obj. 16B Students must draw LINE SEGMENTS, not rectangles or pictures of rulers, etc.

Name _____ Date _____

Part 6: Review of Strand 16 - 17

(16A)

1. Use your ruler or the ruler at the bottom of this page to measure the length of the banner to the nearest centimeter.

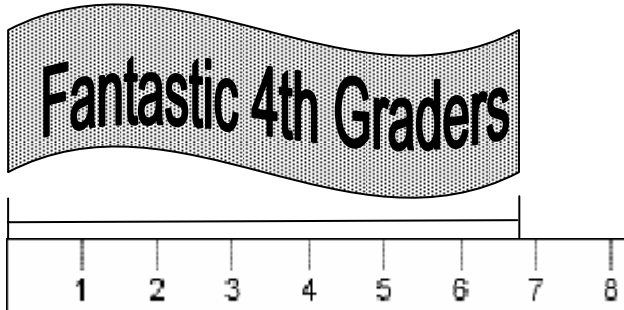

Length: 7 cm

2. Use your ruler to measure the line segment to the nearest half-inch.

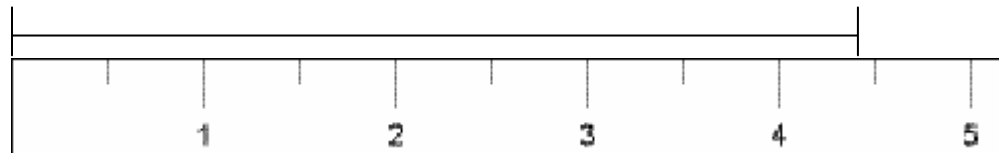

Length: $4\frac{1}{2}$ inches

[Picture this ruler without the black border.]

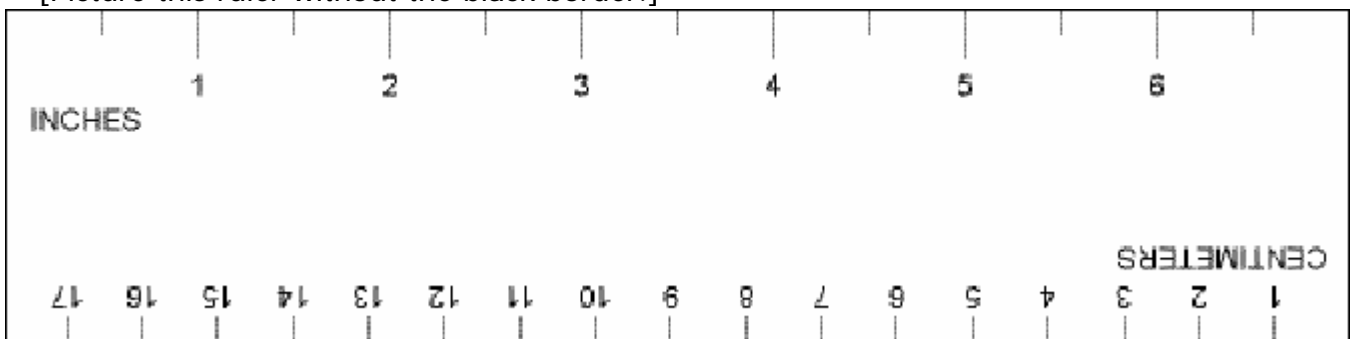

(16A)

3. Use your ruler to measure the height of the robot to the nearest inch.

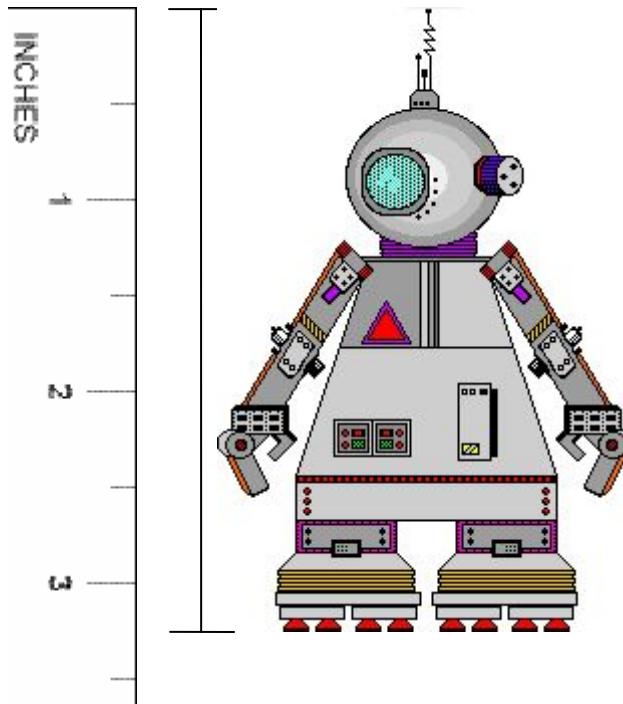

- 3 ***
- 4
- 5
- 6

(16B)

4. Use your ruler to draw a line segment $1\frac{1}{2}$ inches long in the box below.

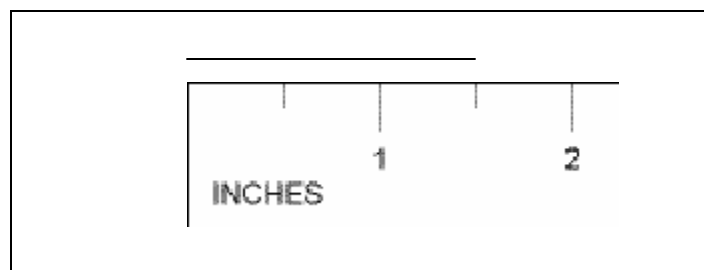

6. Use your ruler to draw a line segment that is 6 centimeters long.

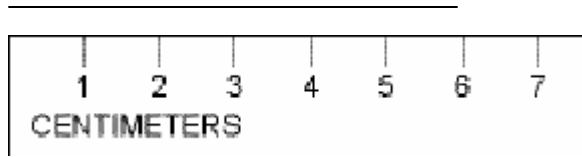

(16C)

7. The length of the gym floor is **best** measured in

- inches
- yards ***
- centimeters
- miles

(16C)

9. What is a **reasonable** width for your fingernail?

- 1 meter
- 1 centimeter ***
- 1 kilometer
- 1 yard

(16C)

8. Which object would be **about** 2 meters tall?

- a grasshopper
- a paper clip
- a refrigerator ***
- a high-rise building (skyscraper)

(16C)

10. Which object would be about 2 **centimeters** tall?

- a student desk
- a tree
- a building
- a stamp ***

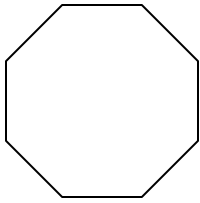

(17A)

11. How many angles does this shape have?

- 3
- 4
- 6
- 8 ***

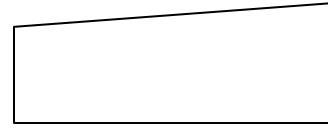



(17A)

13. What is the name of the shape?

- pentagon
- parallelogram
- equilateral triangle
- trapezoid ***

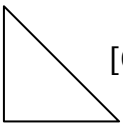
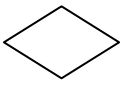
12. Which shape is a quadrilateral?

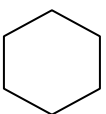
-  [Only 3 sides]
-  *** [rhombus]
-  [5-sided pentagon]
-  [6-sided hexagon]

(17A)

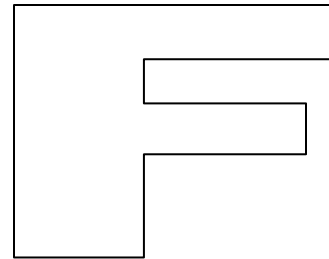

(17A)

14. How many sides does the shape have?

- 3
- 6
- 10 ***
- 12

(17A)

15. What is the name of a polygon that has 5 angles?

- Hexagon
- Pentagon ***
- Trapezoid
- Parallelogram

(17B)

16 Draw a ring around all the objects below that are polygons.

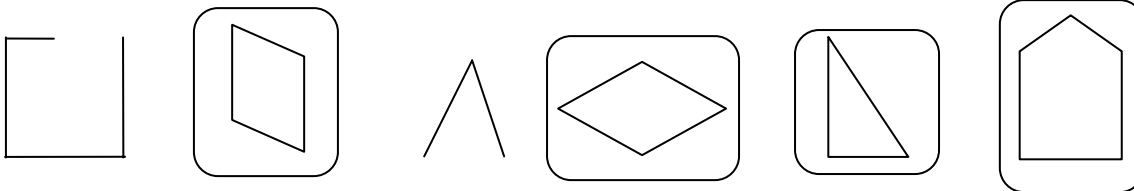

Problem 16 Scoring Rubric:

2 Points – Student circles all 4 polygons and nothing else

1 Point – Student demonstrates partial understanding by circling or identifying 2 or 3 polygons, but does not circle shapes that are not polygons.

0 Points – Student indicates that he/she does not know the crucial attributes of polygons (closed shapes with 3 or more sides)

- by circling 1 or 0 polygons and/or
- by circling 1 or both of the “nonpolygons”

17. Draw a **parallelogram** inside the hexagon.

(17B)

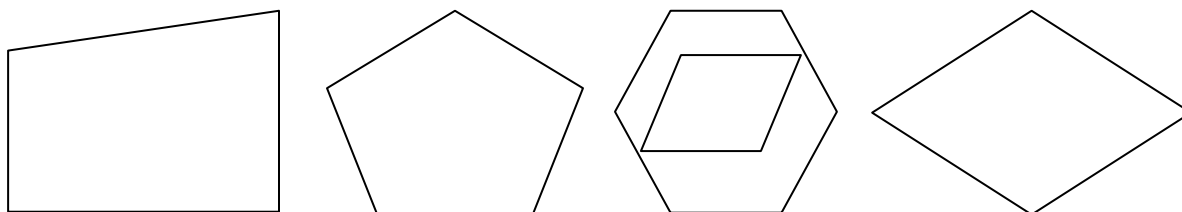

Scoring Rubric for Problem 17:

2 Points: Correctly draws a parallelogram inside the hexagon

1 Point: Either correctly draws a parallelogram

Or draws a shape (not a parallelogram) inside the hexagon

0 Points: Does not draw a parallelogram

AND does not draw a shape inside the hexagon

Scoring Rubric for Drawing a Geometric Figure:

- 1 Point: The student draws a geometric figure as prompted.
 - ~ Reasonable representation of the figure
 - ~ Critical attributes of the figure present
- 0 Points: The student does not indicate that he or she knows the critical attributes of the figure.
 - ~ Figure incorrect
 - ~ Drawing in which the figure is not obvious
- The student may add to the drawing without being penalized. If the figure is recognizable in the drawing, the “embellishments” will be ignored.
- Parallelograms have 4 sides, with opposite sides parallel. If a student draws a square, a rectangle, or a rhombus – accept these shapes as correctly drawn parallelograms. They are all special parallelograms.

(17B)

18. Draw a **pentagon**. Then write a sentence (or more) to explain what makes a shape a pentagon.

Answer: Any 5-sided polygon is correct. A regular polygon (that has 5 equal sides) is not necessary.

Critical Attributes that should be included in explanation: has 5 sides and is closed
The word "polygon" includes the idea of a closed shape.

Example: A pentagon is a 5-sided polygon.

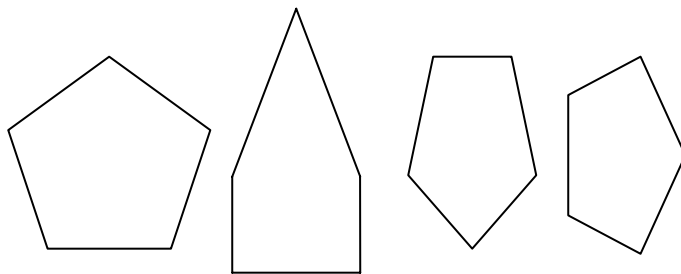

(17B)

19. Draw a **trapezoid**. Then explain why the shape you drew is a trapezoid.

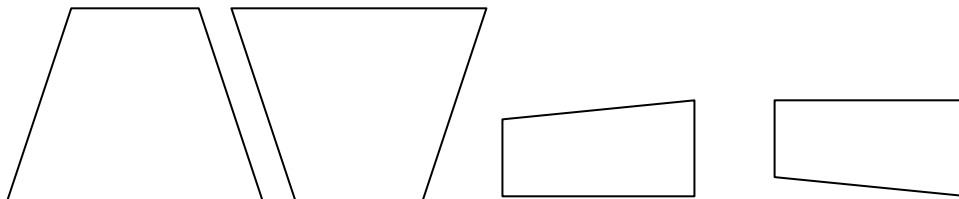

Critical Attributes of a trapezoid:

- has 4 sides or is a quadrilateral
- is a polygon or is a closed shape
- has no pairs of parallel sides